

Rumford Fireplace

Instructions

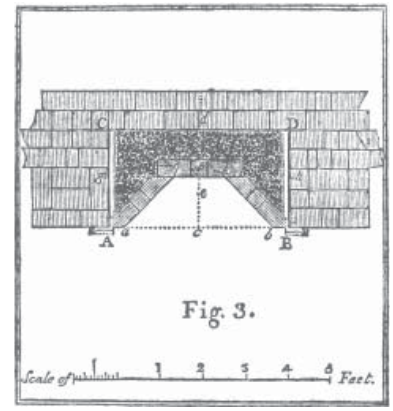

Table of Contents

Foundation and Preparation	2
Hearth Base Dimensions	2
Laying the Inner Hearth	3
Inner Hearth Dimensions	4
Constructing the Firebox	5
Face Opening Dimensions	5
Setting the Rumford Throat	6
Preparing and Installing the Damper	6
Installing and Positioning the Smoke Dome	8
Setting the 1st Flue and Building the Chimney	9
Recommended Flue Sizes	9
Optional Round Flue Adapter	9
The Interior Surround	10
Appendix A. Clearances and Other Information	11

Step 1. Foundation and Preparation

Prepare the supporting foundation for a Rumford using the same construction practices as for a traditional masonry fireplace. Figure 1 shows a cross section for a Rumford and how the components fit into the total fireplace. Table 1 lists the minimum hearth base dimensions required for each size of Rumford.

As with all masonry construction, the foundation must be adequately designed to support the weight of the fireplace and chimney. Some typical construction designs are shown in Figure 2. Local building codes should be reviewed for specific requirements concerning foundation construction. For the minimum requirements contained in most building codes please refer to BIA Technical Notes on Brick Construction, Residential Fireplace Design 19 at <http://www.gobrick.com/Portals/25/docs/TechnicalNotes/TN19.pdf>

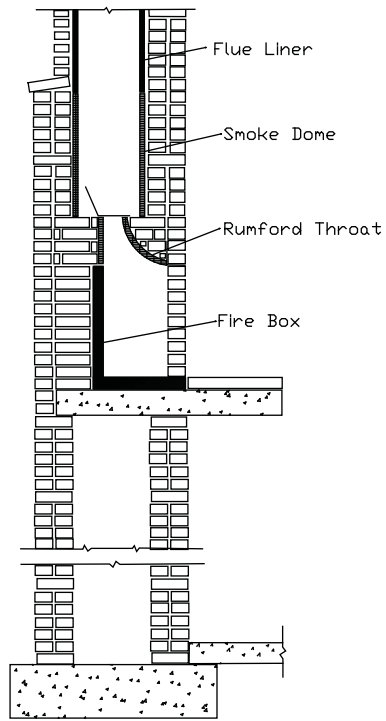

Figure 1. Side Cross Section of a Rumford Fireplace

Table 1a. Minimum Hearth Base Rough Dimensions

Rumford Size	Minimum Width	Minimum Depth ¹
30" Rumford	4'-6"	3'-8"
36" Rumford	5'-0"	4'-0"
42" Rumford	5'-6"	4'-0"
48" Rumford	6'-0"	4'-4"

¹Includes outer hearth base

Table 1b. Minimum Hearth Base Rough Dimensions (Metric)

Rumford Size	Minimum Width	Minimum Depth ¹
30" Rumford	137 cm	112 cm
36" Rumford	152 cm	122 cm
42" Rumford	168 cm	122 cm
48" Rumford	183 cm	132 cm

¹Includes outer hearth base

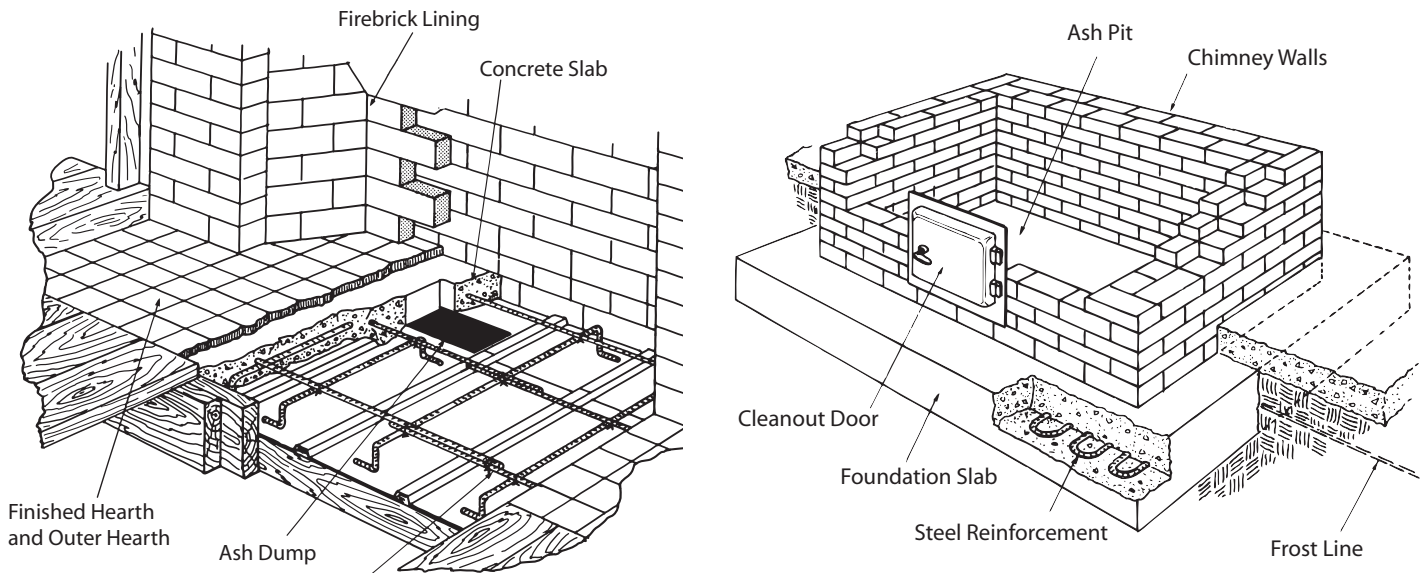

Figure 2. Examples of Typical Foundation Construction

Step 2. Laying the Inner Hearth

See Table 2 and Figure 3 for the hearth dimensions that correspond to the Rumford that is being built. Lay out the firebrick on the prepared foundation base so that the bricks cover the inner hearth and accommodate the walls (Fig 4). The floor hearth bricks should just cover the area required by the inner floor and sidewalls. Mortar inner hearth bricks to the hearth support with an approved refractory mortar using a 1/16" to 1/8" (2-3 mm) joint.

Note: Jobsite prepared fireclay mixes containing Portland and dry milled fireclay do not meet national or state building codes. They do not resist temperature cycling in this application, nor do they possess the necessary acid resistance for this service. Approved refractory mortars (Fig. 5) are required for use in mortar joints for the firebox, smoke dome and flue linings in masonry fireplaces.



Refractory mortar is **required** by building code for the construction of the internal components of masonry fireplaces (firebox, smoke dome, throat, flue liners, etc.).

Refractory mortars are available in 2 forms: *Dry Mix* and *Premix*

Dry mix refractory mortar is suited for all aspects of masonry fireplace construction where refractory mortar is required.

Premix refractory mortar can only be used for components that **do not** come in contact with weather (i.e. firebox) because it will wash out. *Premix* refractory mortar should never be used in outdoor fireplace construction.

Table 2a.

Interior Hearth Dimensions					
	A	B	C	Θ	γ
30" Rumford	30"	12.5"	13.5"	57°	123°
36" Rumford	36"	14"	13.5"	51°	129°
42" Rumford	42"	15"	15"	48°	132°
48" Rumford	48"	16"	18"	47°	133°

Table 2b.

Interior Hearth Dimensions					
	A	B	C	Θ	γ
30" Rumford	762 mm	318 mm	343 mm	57°	123°
36" Rumford	914 mm	356 mm	343 mm	51°	129°
42" Rumford	1067 mm	381 mm	381 mm	48°	132°
48" Rumford	1219 mm	406 mm	457 mm	47°	133°

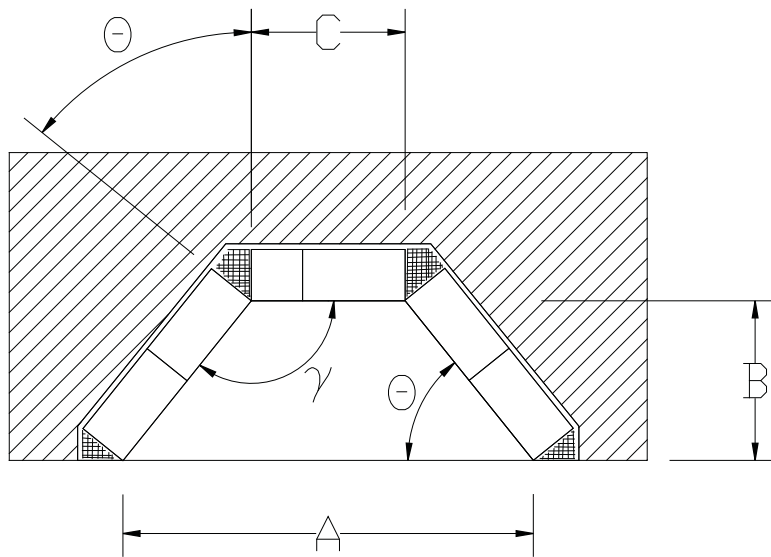

Figure 3. Hearth--Plan View



We recommend that firebrick be positioned 4½" x 2½" x 9" (11mm x 6mm x 23mm) (stretchers) as opposed to shiners laid 2½" x 4½" x 9" (6mm x 11mm x 23mm) to yield a high quality, geometrically stable and durable firebox (Fig 6 and 7).



Figure 4. Interior Hearth Rough Layout



Figure 5. Examples of Approved Refractory Mortar Brands

Step 3. Constructing the Firebox

Construct the walls of the firebox according to the dimensions provided in Table 3 that correspond to the size of the fireplace. Use approved refractory mortar maintaining 1/16” to 1/8” (2-3mm) joints. Be sure to use proper back-up behind the firebox with appropriate fill. 75% solid concrete blocks are preferred. Be sure to maintain proper clearances to combustibles throughout construction. See Appendix A for a summary of clearances and other code considerations.



Figure 6. Completed Firebox Wall Construction



Figure 7. Stretchers



vs. Shiners

Table 3a.

Face Opening	Width	Height
30” Rumford	30”	27-32”
36” Rumford	36”	32-38”
42” Rumford	42”	38-42”
48” Rumford	48”	42-48”

Table 3b.

Face Opening	Width	Height
30” Rumford	762 mm	686-813 mm
36” Rumford	914 mm	813-965 mm
42” Rumford	1067 mm	965-1067 mm
48” Rumford	1219 mm	1067-1219 mm

Step 4. Setting the Rumford Throat

After completion of the firebox walls to the specified height, set and mortar the throat to the firebox with refractory mortar (Fig. 8). The inside back three (3) walls of the throat should be flush with the inside walls of the fire box (Fig. 9). No inside ledges.



Figure 8. Setting the Rumford Throat



Figure 9. Back Walls of Throat Sitting Flush with Fire Brick

Step 5. Preparing a Base and Installing the Flat Damper

Build up the surrounding masonry to match the elevation of the top of the throat (Fig. 10).

Place reinforcing rod or a steel lenti with the first row of masonry that crosses the front of the throat to enhance support over the opening.

Build up the masonry, preparing a flat surface onto which the damper and smoke dome can be placed and mortared (Fig.11). When setting the damper (Fig 12), make sure that it will operate properly in conjunction with all surrounding masonry. Check and correct for any interferences in opening, closing or overall operation of the damper.



Figure 10. Building Up the Masonry to Create a Setting Surface for the Damper and Smoke Dome



Figure 11. Setting the Damper



For outdoor fireplace construction, a damper is not necessary.

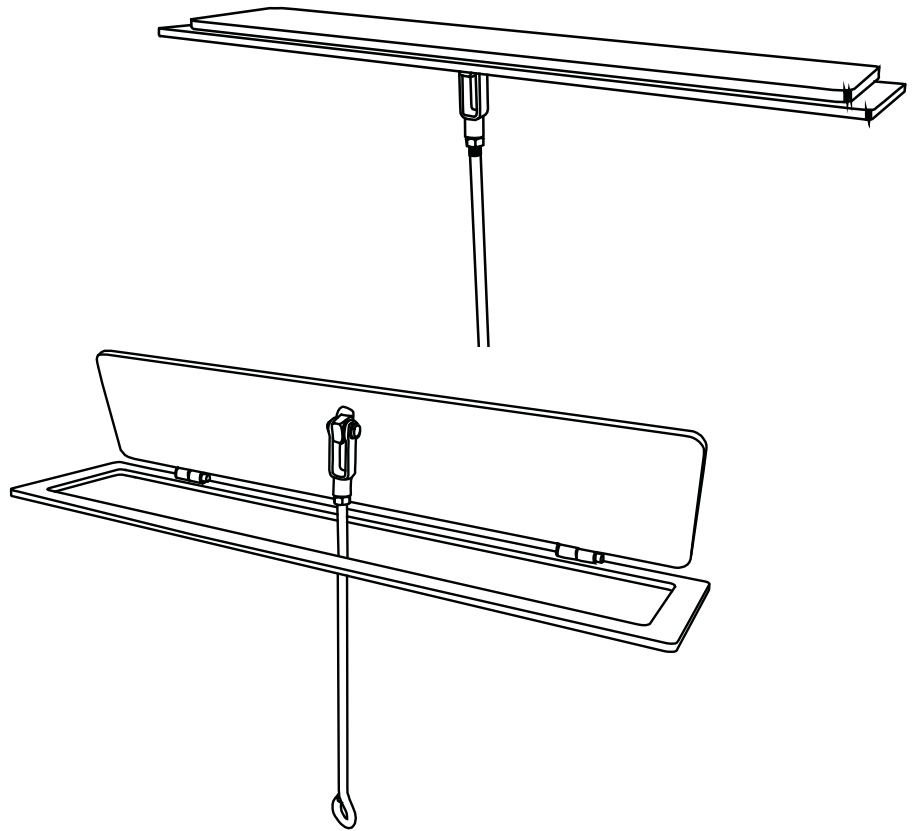

Figure 12. Flat Damper

Step 6. Positioning the Smoke Dome

Place the smoke dome onto the prepared flat surface fitting it over the top of the damper. If necessary, adjust the elevation of the smoke dome to insure that the damper opens and closes properly and clears the sides of the smoke dome. The position of the smoke dome can be adjusted front to back or left to right in order to line up with the chimney. Make sure that when the damper is operated that it clears the sides of the smoke dome. Be sure to mortar the smoke dome to the platform and mortar all sections together (Fig. 13a, 13b and 14).



Figure 13a and 13b. Setting the Smoke Dome

Smoke Dome Dimensions					
	H	Base OD	Base ID	Top OD	Top ID
30" & 36" Rumford	19"	13"x 35"	11"x 32"	13"x 13"	11"x 11"
42" Rumford	30"	13"x 35"	11"x 32"	13"x 17½"	11"x 15½"
48" Rumford	30"	15½"x 35"	13½"x 32"	15½"x 19½"	13½"x 17"

Smoke Dome Dimensions					
	H	Base OD	Base ID	Top OD	Top ID
30" & 36" Rumford	480 mm	330x890mm	279x813mm	330x330mm	279x279mm
42" Rumford	762 mm	330x890mm	279x813mm	330x445mm	279x394mm
48" Rumford	762 mm	394x890mm	342x813mm	394x495mm	342x432mm

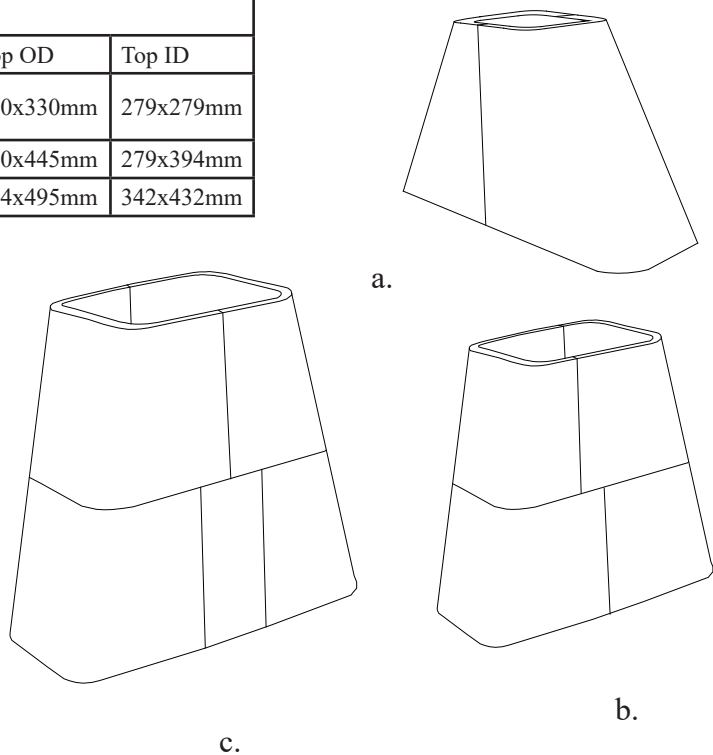

Figure 14. Smoke Dome Sections for a.) 30" & 36" Rumford--2 pieces, b.) 42" Rumford--4 pieces and c.) 48" Rumford--6 pieces.

Step 7. Setting the 1st Flue Liner and Building the Chimney

Using refractory mortar, attach the first flue liner to the smoke dome and proceed with normal chimney construction (Fig. 15). If using a round flue liner and transition ring, position and mortar the transition piece onto the smoke dome and proceed with normal chimney construction

Recommended flue sizes and transition rings are listed in Table 4.

Take care that all interior transitions are smooth and free of mortar and other obstructions to eliminate horizontal surfaces onto which creosote might accumulate during operation.

For any questions regarding chimney construction details, please refer to BIA Technical Notes 19b at: <http://www.gobrick.com/Portals/25/docs/TechnicalNotes/TN19B.pdf>



Figure 15. Starting the Chimney from Smoke Dome

Table 4.

	Flue Size	Transition to Round Flue
30" Rumford	12" Round, 13x13 or 12x12	Not Necessary
36" Rumford	12" Round or 13x13	Not Necessary
42" Rumford	15" Round or 13x18	Available
48" Rumford	18" Round or 16x20	Available

Step 7a. Optional Round Flue Adapter

An adapter piece is available for the 42" and 48" Rumford that will convert the square/rectangle opening on the smoke dome to a round opening that is properly sized for the fireplace (Fig. 16). To install, simply mortar the adapter to the smoke dome and proceed with normal construction using round flues.

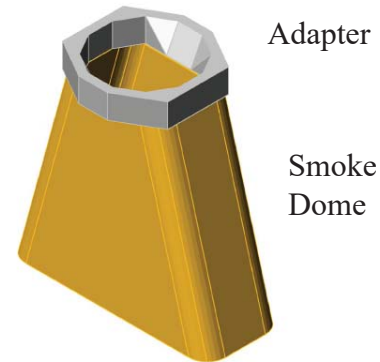

Figure 16. Rectangle/Square to Round Adapter



The 30" & 36" Rumford does not require an adapter. A 12" round flue nicely fits the 13x13 opening and can be mortared directly to the 30"/36" smoke dome.



Round flue liners, especially in the larger sizes, are significantly less costly and efficient than the equivalent square/rectangle. Be sure to compare prices.

Step 8. The Surround

Complete the surround in the same manner as with any other fireplace (Fig. 17).



Figure 17. Fireplace Ready for Surround Installation



It is important to make sure that the facing does not drop below the front edge of the throat (Fig 18). Dropping below this elevation will impede the airflow and possibly create a smoking situation.

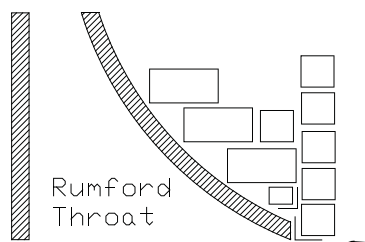
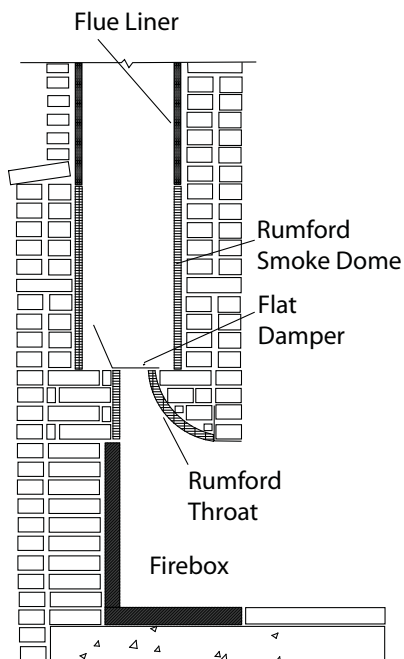

IMPORTANT: Do not allow facing to fall below this point. The Surround cannot be lower than the bottom front edge of the throat.

Figure 18. Surround Installation Detail

Appendix A. Clearance to Combustibles (and other important details to avoid mistakes and code violations)

Framing

All combustibles must be a minimum of 2” away from the masonry

If the fireplace is on an outside wall, combustibles must be 4” from the masonry.

Framing headers must be at a minimum of 3’0” above the top of the fireplace opening as well as 2” away from the masonry.

Fireplace

Firebrick must be backed up with 75% solid masonry creating walls minimum of 8” thick.

The masonry surrounding the smoke chamber must be a minimum of 6” thick measured from the outside to the interior wall.

A non-combustible surround must extend a minimum of 6” beyond the interior face of the fireplace.

Chimney

The size of flue liner is determined by the inside face opening of the fireplace. The flue cross-sectional area required must be a minimum of 10% of the cross-sectional area of the interior face opening. If using round flues, 8% cross-sectional area may be used.

There must be a minimum of 2” airspace between the outside of the flue liner and the chimney wall.

The chimney wall must be a minimum of 4” thick solid masonry.

The chimney must terminate a minimum of 3’0” from the roof and a minimum of 2’0” from a higher point within 10’ of the chimney.

The instructions provided are intended as a guideline for installing the prefabricated Rumford components as a part of a masonry fireplace. Proper fireplace construction techniques, compliance with building codes and any other requirements are the responsibility of the masonry contractor/installer. Sandkuhl Clay Works, Inc. is not responsible for any errors or misrepresentations that this instruction document may contain or any construction/finished installation problems that may result.